

MOTOMAN HC10DTP Classic

Human-Collaborative Robot

6 integrated Sensors

with internal Cable Routing



The MOTOMAN HC10DTP Classic Cobot is the perfect entry-level model for automating your production. With a payload of 10 kg and a reach of 1,379 mm, this cobot is particularly suitable for material handling such as palletizing, packaging or pick & place.

The MOTOMAN HC series from Yaskawa has been developed for easy entry into robot automation. Besides our easy programming philosophy with Smart Pendant and Direct Teaching, our new online tutorials and the online application builder facilitates your first steps in robotic automation.

On the intuitive Smart Pendant interface, you are guided through all the single steps – various visualisation menus provide you the perfect overview of your application – from programming to safety configuration.

Robot programs can be created either conveniently on the tablet-based Smart Pendant – by pressing the hand-guide buttons on the cobot's flange – or with the proven Teach Pendant for complex tasks.

A broad range of compatible Yaskawa products as well as Plug & Play partner products from the Yaskawa ecosystem make it easy to implement various systems in all application areas. The ISO flange and configuration wizards simplify the installation of grippers in particular.

Due to the integrated torque sensors in each joint, the robot can be used in human-robot collaboration without a protective fence.

KEY BENEFITS

Easy-to-use

- Simple programming with Smart Pendant incl. Smart Frame and hand guiding
- Complex programming with Teach Pendant
- Pendants with standard 3-position enabling switch
- Wizard programming for applications and accessories
- Ecosystem of Plug & Play partner products
- ISO flange for easy connection of accessories
- Yaskawa simulation software MotoSim EG VRC

Smart safety

- PL d Cat. 3 certification with 25 safety-related hardware and software functions
- High-resolution torque sensors in each joint
- Easy configuration of the safety unit, such as definition of ranges, plains and precise envelopes for manipulator and gripper
- Two retract movements: Retract & Clamp Release function
- Pushback function for pushing the robot away during operation

Industrial design for hybrid operation

- Robust aluminium cast in lightweight design
- Internal media routing
- Automatic calibration
- Fast axis speeds
- Industrial control options YRC1000 and YRC1000micro

Controlled by
YRC1000

Controlled by
**YRC1000
micro**

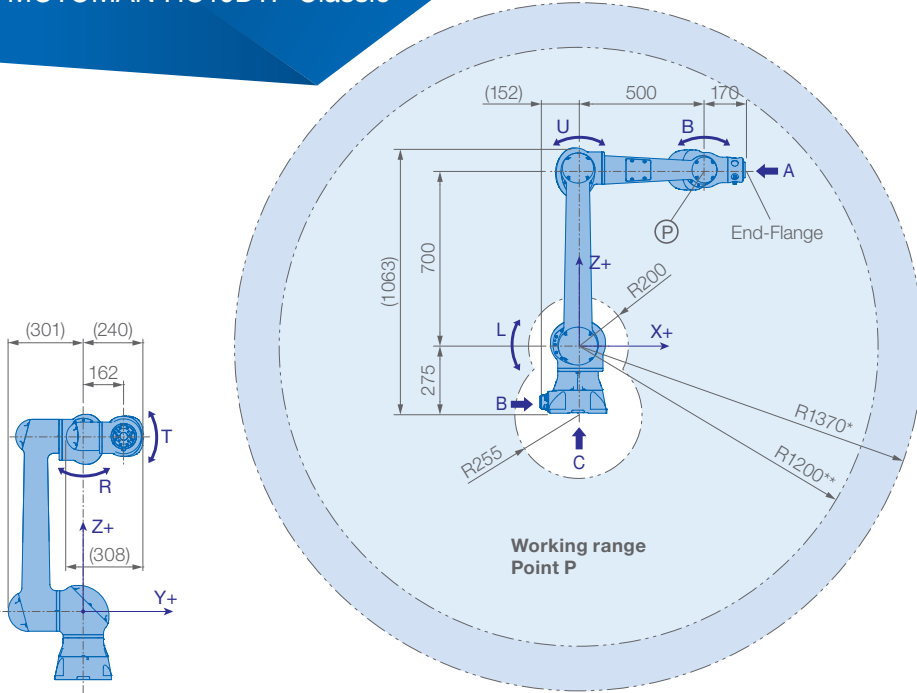

* Absolute reach: S/L-Axis center of rotation to R/T-Axis center of rotation
 ** Effective reach: S/L-Axis center of rotation to Point P

View A

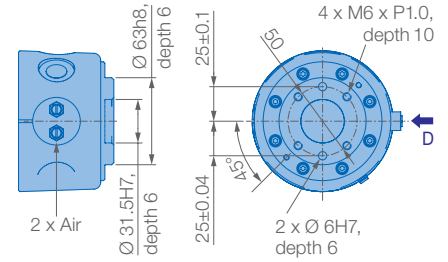

View B

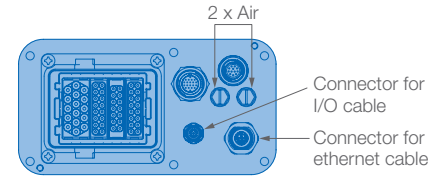

View C

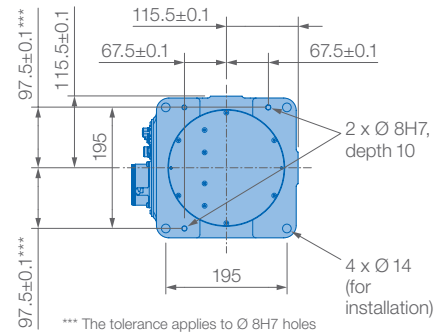

Mounting options: Floor, ceiling, wall, tilt*
 IP Protection: IP20

* S Axis motion limits – see table left side

View D

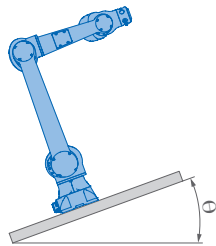
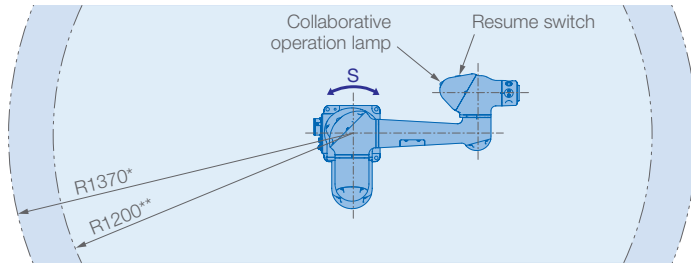

Robot installation angle θ [deg.]	S-axis operating range [deg.]
$0 \leq \theta \leq 60$	no limit
$60 < \theta$	± 60 max.

Allowable wrist load

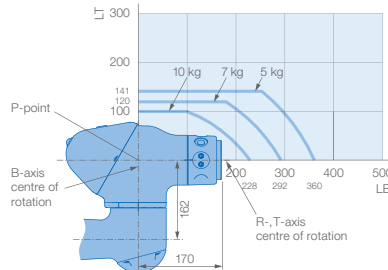

Specifications HC10DTP Classic					
Axes	Maximum motion range [°]	Maximum speed [°/s]	Allowable moment [Nm]	Allowable moment of inertia [kg · m ²]	Controlled axes
S	± 210	130	–	–	6
L	± 180	130	–	–	Max. payload [kg]
U	± 290	180	–	–	Repeatability [mm]
R	± 210	180	27.4	0.78	Max. working range R [mm]
B	± 180	250	27.4	0.78	Temperature [°C]
T	± 210	250	9.8	0.1	Humidity [%]
					Weight [kg]
					Power supply, average [kVA]

* Absolute reach: S/L-Axis center of rotation to R/T-Axis center of rotation ** Effective reach: S/L-Axis center of rotation to Point P

Yaskawa Europe GmbH

Robotics Division
 Yaskawastraße 1
 85391 Allershausen
 Germany

Tel. +49 (0) 8166 90-0
 robotics@yaskawa.eu
 www.yaskawa.eu

YR-1-06VXCP10-A00
 A-02-2022, A-No. 220872